

Thru holes KG, DK, SK are for Kelvin contact.  
If Kelvin Contact is not required,  
these holes are not necessary.

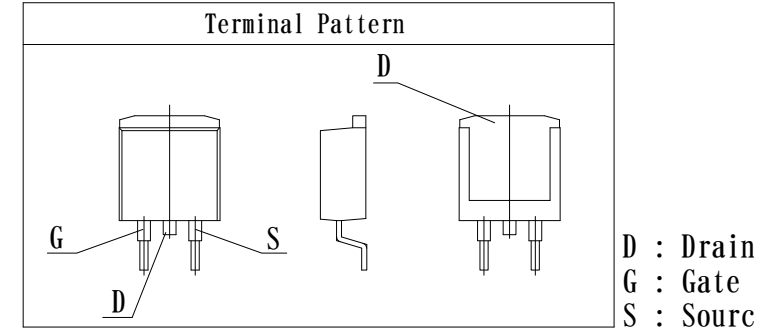
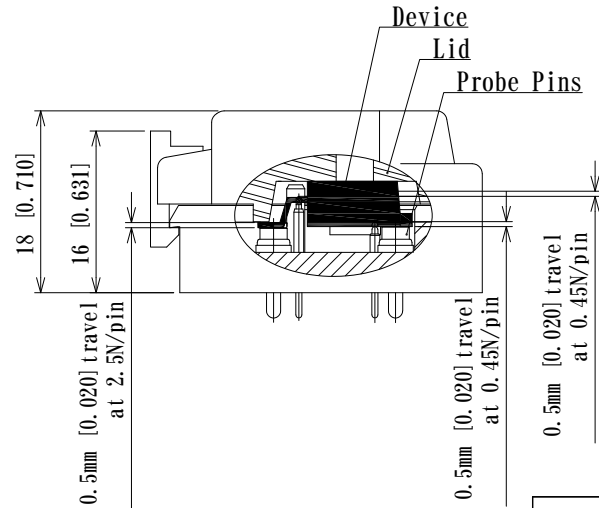
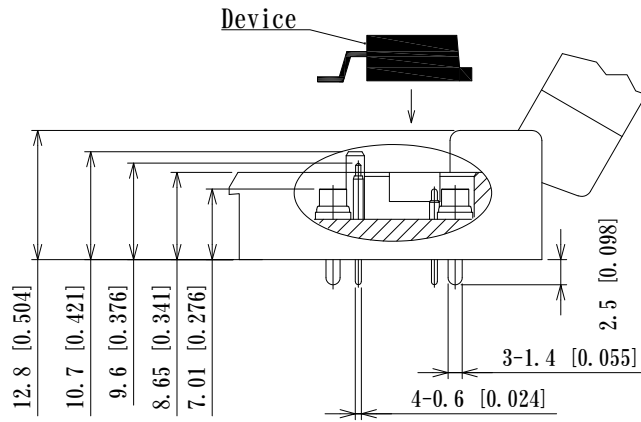

**SPECIFICATION**

- DURABILITY** : 100,000 cycle (Mechanical)
- CONTACT RESISTANCE** : 50mΩ max (Socket initial)
- CURRENT RATING** : 10A at 25°C (Between Drain and Source)  
Room temperature with 30°C T-Rise
- WITHSTANDING VOLTAGE** : DC2000V 1 minute at 25°C
- INSULATION RESISTANCE** : 500MΩ min at DC500V
- OPERATING TEMPERATURE** : -40°C ~ +200°C (Including Probe pin T-Rise.)

<b>Date</b>		<b>JC ELECTRONICS CORPORATION</b>
2023/08/18		
<b>Materials Finish</b>		Body : High Temp Thermoplastic Other parts : SUS, etc.
<b>Dimensions Style</b>		<b>Title</b>
mm [inch]		T0263 TEST SOCKET
Third Angle Projection		<b>Part Number</b>
Rev. No		<b>GD18-T0263-K-109</b>
0		